

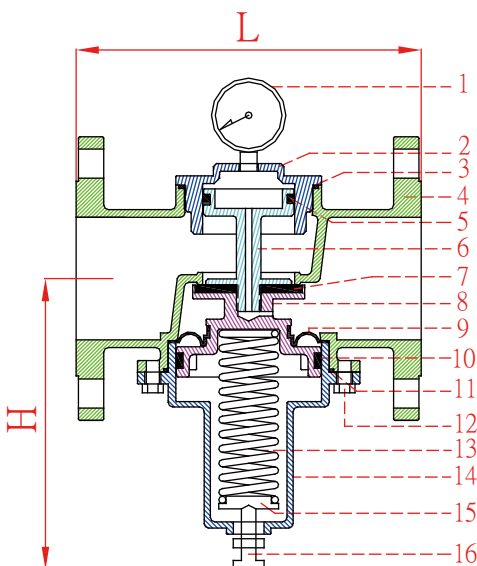

DIRECT-ACTIVATED PRESSURE SUSTAINING / BACK PRESSURE VALVE

- ▶ The whole set is made by stainless steel #316, and it is suitable for the fluid of pure water, acid & alkaline fluid, steam or air.
- ▶ Back pressure valve can maintain required pressure.
- ▶ Design of piston and diaphragm improves the inability of sustaining pressure and leakage.
- ▶ Back pressure chamber controls the valve gate and let gate respond, quickly and adjust pressure accurately.

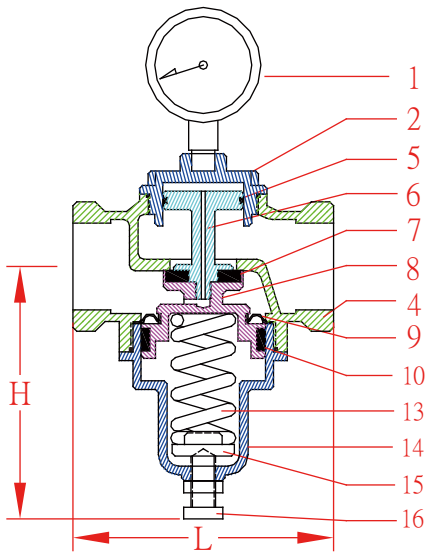

- ▶ Pressure Adjusting Range : 1 ~ 5 kgf/cm²
4 ~ 10 kgf/cm²
- ▶ Pressure needed from fully-closed gate to fully-opened gate:
1.5 kgf/cm² (1 kgf/cm² = 14.2 psi)
- ▶ Applied Temperature : -15 ~ 100°C
100 ~ 180°C (For steam)
- ▶ Valve Body Testing Pressure : 35 kgf/cm²
- ▶ Maximum Applied Pressure : 25kgf/cm²
- ▶ Pressure gauge indicates the sustaining pressure.

No	Part Name	Material
1	Gauge	Stainless Steel
2	Upper Cover	Stainless Steel 316
3	O-ring	NBR / Viton
4	Main Body	Stainless Steel 316
5	U-ring	NBR / Viton
6	Shaft	Stainless Steel 316
7	Sealing Spacer	NBR / Viton / Teflon
8	Seat	Stainless Steel 316
9	Diaphragm	CR/ EPDM/ Viton
10	UH-ring	NBR / Viton
11	O-ring	NBR / Viton
12	Fixed Bolt	Stainless Steel 304
13	Spring	Spring Steel
14	Lower Cover	Stainless Steel 316
15	Washer	Brass
16	Adjusting Stem	Stainless Steel 304

(Thread Type)

Item No	Size	H(mm)	L(mm)	Weight(kg)	CV
RFT15-S	1/2"	80	70	0.8	2.4
RFT20-S	3/4"	105	85	0.9	9.0
RFT25-S	1"	105	92	1.0	11.0
RFT40-S	1 1/2"	130	115	2.2	21.0
RFT50-S	2"	130	120	3.1	25.0

(Flange Type)

Item No	Size	H(mm)	L(mm)	Weight(kg)	CV
RFF15-S	1/2"	85	150	2.0	2.4
RFF20-S	3/4"	105	150	2.8	9
RFF25-S	1"	105	150	3.5	11
RFF40-S	1 1/2"	130	190	5.1	21
RFF50-S	2"	130	190	5.9	25
RFF65-S	2 1/2"	185	210	6.5	75
RFF80-S	3"	185	225	11.5	80
RFF100-S	4"	230	250	12.0	120
RFF150-S	6"	290	310	19.0	250