

HGO

series



UL O.S&Y Gate Valve – Flange Ends

- Size: 2.5"(DN65) to 12"(DN300)
- Working Pressure: 300 PSI
- Test Pressure: 600 PSI
- Working Temp.: 0°C to 80°C (32°F to 176°F)
- Valve Standard: UL262,ULC/ORD C262-92
- Connection Standard: Flange: ASME/ANSI B16.1 Class 125 or ASME/ANSI B16.42 Class 150 or BS EN1092-2 PN16 or GB/T9113.1
- Face to Face Standard: ASME B16.10
- Test Standard: UL262,ULC/ORD C262-92



HGO-300FF

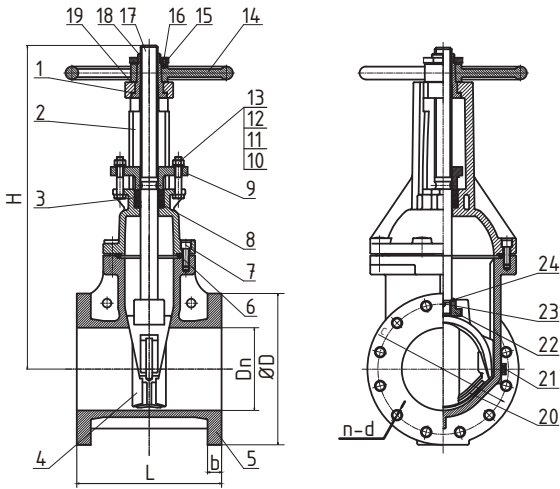

ITEM	PARTS	MATERIAL
1	GASKET	C28000
2	BONNET	DI
3	PACKING	PTFE
4	DISC	EPDM+DI
5	BODY	DI
6	SEALING RING	EPDM
7	BOLT	Steel
8	SEAL GASKET	EPDM
9	GLAND	DI
10	NUT	S. S. 304
11	FLAT WASHER	Steel
12	BOLT	S. S. 304
13	SPRING WASHER	Steel
14	HANDWHEEL	DI
15	LOCK NUT	C954
16	LOCATING SCREW	S. S. 304
17	STEM	S. S. 304
18	STEM NUT	C954
19	GASKET	C28000
20	SKELETON	DI
21	PLUG	C28000
22	LIFTING NUT	CF8M
23	PIN	S. S. 304
24	SEALING RING	EPDM

SIZES		DIMENSIONS (MM)					
Inch	mm	L	D	b	c	n-d	H
2.5	DN 65	190	178	17.5	139.5	4-Ø19	357
3	DN 80	203	191	21	152.5	4-Ø19	411
4	DN 100	229	229	24	190.5	8-Ø19	443
5	DN 125	254	254	23.9	216	8-Ø22	536
6	DN 150	267	279	25.4	241.5	8-Ø22	595
8	DN 200	292	343	28.6	298.5	8-Ø22	739
10	DN 250	330	406	30.2	362	12-Ø25	881
12	DN 300	356	483	31.8	432	12-Ø25	1021